

TLS-55 Rotor



**Used in Beckman Coulter
Optima™ MAX, MAX-E, TL,
and TLX Series
Tabletop Ultracentrifuges**



SAFETY NOTICE

This safety notice summarizes information basic to the safe use of the rotor described in this manual. The international symbol displayed above is a reminder to the user that all safety instructions should be read and understood before operation or maintenance of this equipment is attempted. When you see the symbol on other pages throughout this publication, pay special attention to the specific safety information presented. Observance of safety precautions will also help to avoid actions that could damage or adversely affect the performance of the rotor. This rotor was developed, manufactured, and tested for safety and reliability as part of a Beckman Coulter ultracentrifuge/rotor system. Its safety or reliability cannot be assured if used in a centrifuge not of Beckman Coulter's manufacture or in a Beckman Coulter ultracentrifuge that has been modified without Beckman Coulter's approval.



Handle body fluids with care because they can transmit disease. No known test offers complete assurance that such fluids are free of micro-organisms. Some of the most virulent—Hepatitis (B and C) viruses, HIV (I–V), atypical mycobacteria, and certain systemic fungi—further emphasize the need for aerosol protection. Handle other infectious samples according to good laboratory procedures and methods to prevent spread of disease. Because spills may generate aerosols, observe proper safety precautions for aerosol containment. Do not run toxic, pathogenic, or radioactive materials in this centrifuge without taking appropriate safety precautions. Biosafe containment should be used when Risk Group II materials (as identified in the World Health Organization *Laboratory Biosafety Manual*) are handled; materials of a higher group require more than one level of protection.



The rotor and accessories are not designed for use with materials capable of developing flammable or explosive vapors. Do not centrifuge such materials in nor handle or store them near the ultracentrifuge.



Although rotor components and accessories made by other manufacturers may fit in the TLS-55 rotor, their safety in this rotor cannot be ascertained by Beckman Coulter. Use of other manufacturers' components or accessories in the TLS-55 rotor may void the rotor warranty and should be prohibited by your laboratory safety officer. Only the components and accessories listed in this publication should be used in this rotor.



Hook all four buckets, loaded or empty, to the rotor for every run. Make sure that filled containers are loaded symmetrically into the rotor and that opposing tubes are filled to the same level with liquid of the same density. Make sure that buckets containing Quick-Seal tubes have the proper floating spacers inserted (if applicable) before installing the bucket cap.



If disassembly reveals evidence of leakage, you should assume that some fluid escaped the rotor. Apply appropriate decontamination procedures to the centrifuge and accessories.



Never exceed the maximum rated speed of the rotor and labware in use. Refer to the section on RUN SPEEDS, and derate the run speed as appropriate.



Do not use sharp tools on the rotor that could cause scratches in the rotor surface. Corrosion begins in scratches and may open fissures in the rotor with continued use.

TLS-55 Rotor

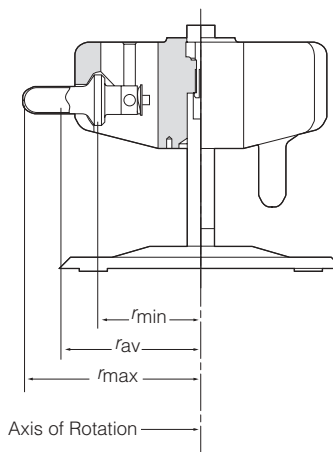

U.S. Pat. No. 4,400,166

SPECIFICATIONS

Maximum speed	55 000 rpm
Density rating at maximum speed	1.7 g/mL
Relative Centrifugal Field* at maximum speed	
At r_{max} (76.5 mm)	259 000 × g
At r_{av} (59.4 mm)	201 000 × g
At r_{min} (42.2 mm)	143 000 × g
k factor at maximum speed	50
k factors at maximum speed (5 to 20% sucrose gradient; 5°C)	
When particle density = 1.3 g/mL	130
When particle density = 1.5 g/mL	119
When particle density = 1.7 g/mL	114
Conditions requiring speed reductions	see RUN SPEEDS
Number of buckets	4
Available tubes	see Table 1
Nominal tube dimensions (largest tube)	11 × 34 mm
Nominal tube capacity (largest tube)	2.2 mL
Nominal rotor capacity	8.8 mL
Approximate acceleration time to maximum speed	
(fully loaded)	3 min
Approximate deceleration time from maximum speed	
(fully loaded)	2 1/2 min
Weight of fully loaded rotor	0.8 kg (1.8 lb)
Rotor body material	aluminum
Bucket material	titanium

* Relative Centrifugal Field (RCF) is the ratio of the centrifugal acceleration at a specified radius and speed ($r\omega^2$) to the standard acceleration of gravity (g) according to the following formula:

$$RCF = \frac{r\omega^2}{g}$$

where r is the radius in millimeters, ω is the angular velocity in radians per second ($2\pi \text{ RPM} / 60$), and g is the standard acceleration of gravity (9807 mm/s^2). After substitution:

$$RCF = 1.12 r \left(\frac{\text{RPM}}{1000} \right)^2$$

DESCRIPTION

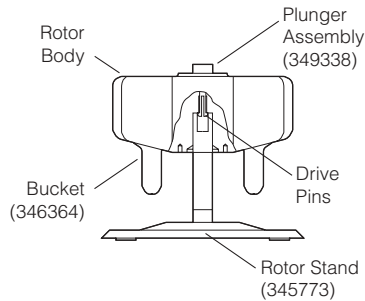

This Beckman Coulter rotor has been manufactured in an NSAI-registered ISO 9001 or 9002 facility for use with the appropriately classified Beckman Coulter ultracentrifuge.

The TLS-55, rated for 55 000 rpm, is a swinging bucket rotor that holds four tubes and is used in Beckman Coulter Optima™ MAX, MAX-E, TL, and TLX series tabletop ultracentrifuges. The TLS-55 rotor develops centrifugal forces that are suitable for rate zonal banding of proteins, viruses, and DNA from small sample volumes.

The rotor body and bucket caps are made of aluminum and are black-anodized for corrosion resistance. The buckets are titanium. Lubricated O-rings made of Buna N maintain atmospheric pressure inside the buckets during centrifugation. Buckets, bucket caps, and rotor body positions are numbered for your convenience. Bucket and cap assemblies are loaded from the top of the rotor; the titanium crossbars slide down into the slots provided in the rotor body. When not in the instrument, the rotor body must be supported on its rotor stand to permit the buckets to hang properly.

A plunger mechanism in the rotor body locks the rotor to the drive hub before the run begins. Engaging the plunger ensures that the rotor remains seated during centrifugation.

The centrifuge identifies rotor speed during the run by means of a magnetic speed sensor system in the rotor chamber of the instrument and magnets on the bottom of the rotor. This overspeed protection system ensures that the rotor does not exceed its permitted speed.

Refer to the Warranty at the back of this manual for warranty information.

PREPARATION AND USE

Specific information about the TLS-55 rotor is given here. Information common to this and other rotors is contained in the manual Rotors and Tubes for Beckman Coulter Tabletop Preparative Ultracentrifuges (publication TLR-IM), which should be used together with this manual for complete rotor and accessory operation. Rotors and Tubes is included in the literature package with this rotor manual.

NOTE

Although rotor components and accessories made by other manufacturers may fit in the TLS-55 rotor, their safety in this rotor cannot be ascertained by Beckman Coulter. Use of other manufacturers' components or accessories in the TLS-55 rotor may void the rotor warranty and should be prohibited by your laboratory safety officer. Only the components and accessories listed in this publication should be used in this rotor.

PRERUN SAFETY CHECKS

Read the Safety Notice page at the front of this manual before using the rotor.

1. Make sure that the rotor, buckets, and caps are clean and show no signs of corrosion or cracking.
2. Check the chemical compatibilities of all materials used (refer to Appendix A in *Rotors and Tubes*).
3. Verify that the tubes and accessories being used are listed in Table 1.

ROTOR PREPARATION

For runs at other than room temperature, refrigerate or warm the rotor beforehand for fast equilibration.

1. Before each use of the rotor, make sure that bucket cap threads are lightly but evenly lubricated with Spinkote™ lubricant (306812), and the bucket O-rings are lightly but evenly coated with silicone vacuum grease (335148).

NOTE

Never run a bucket without an O-ring, as it will leak.

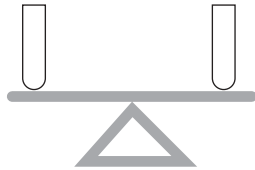

2. Dry the exterior of the filled tubes (see page 8 for tube information), then slide them into the buckets. (Moisture between the bucket and the tube can cause tube collapse and create resistance to tube extraction after centrifugation.) All opposing tubes for a run must be filled to the same level (± 0.1 mL) with liquid of the same density.
3. Use the required adapters or floating spacers, if required, to complete the loading operation.
4. Match numbered caps with numbered buckets. Screw the caps into the buckets until there is metal-to-metal contact.

NOTE

Two tubes can be run if the filled buckets are attached in opposing positions on the rotor (positions 1 and 3, or 2 and 4), *and the two remaining buckets are also attached.* (If you regularly run only two filled buckets, alternate the placement—positions 1 and 3, then 2 and 4—to ensure even wear on the rotor.)

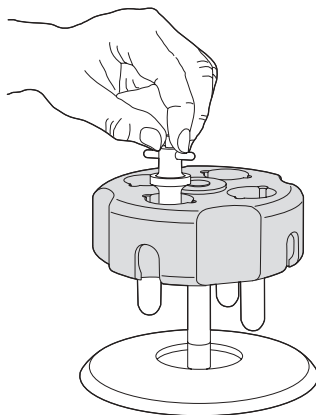

5. Attach numbered bucket assemblies to corresponding rotor body positions. Insert the bucket assembly into the rotor cavity. Attach all buckets, loaded or empty.
6. Slide the crossbar down the grooves until it is seated in the slots.

NOTE

Remember, all four buckets *must be attached to the rotor*, whether they are loaded or empty. Attach the buckets to the rotor before installing it in the instrument. Trying to attach them after the rotor is installed may cause damage to the drive shaft.

OPERATION

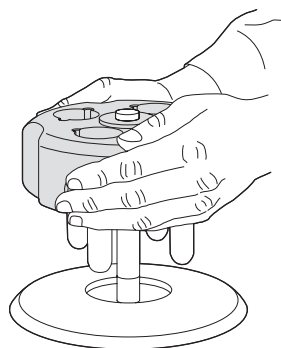

Refer to Rotors and Tubes for information on installing swinging bucket rotors.

1. To install the rotor, carefully lift it with both hands and place it on the drive hub.

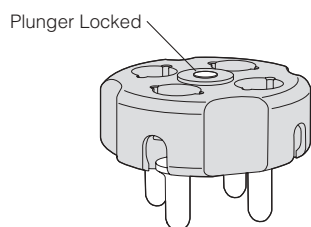

2. Lock the rotor in place by gently pressing the plunger down until you feel it click. When you remove your finger, the plunger will remain flush with the rotor body if it is properly engaged. If the plunger pops up, repeat the procedure.



CAUTION

In all ultracentrifuge models except the Optima MAX and MAX-E, it is very important to lock the rotor in place before beginning the run to ensure that the rotor remains seated during centrifugation. Failure to lock the rotor in place before beginning the run may result in damage to both rotor and instrument.

3. Refer to the instrument instruction manual for ultracentrifuge operation.
4. For additional operating information, see the following:
 - RUN TIMES, page 10, for using k factors to adjust run durations
 - RUN SPEEDS, page 11, for information about speed limitations
 - SELECTING CsCl GRADIENTS, page 13, for methods to avoid CsCl precipitation during centrifugation

REMOVAL AND SAMPLE RECOVERY



CAUTION

If disassembly reveals evidence of leakage, you should assume that some fluid escaped the rotor. Apply appropriate decontamination procedures to the centrifuge and accessories.

Plunger Unlocked

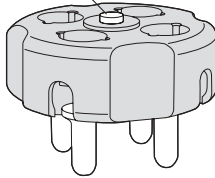

1. To release the plunger at the end of the run, gently press it down until you feel it click. When you remove your finger the plunger will pop up to its released position.
2. Remove the rotor from the ultracentrifuge and return it to its stand.
3. Detach the buckets from the rotor body.
4. Unscrew the bucket caps, then use forceps or a hemostat to remove the tubes.

TUBES AND ACCESSORIES

The TLS-55 rotor uses tubes and accessories listed in Table 1. Be sure to use only those items listed, and to observe the maximum speed limits shown. Refer to Appendix A in *Rotors and Tubes* for information on the chemical resistances of tube and accessory materials.

Temperature Limits

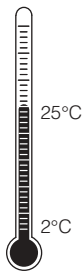

- Plastic tubes and bottles have been centrifuge tested for use at temperatures between 2 and 25°C. For centrifugation at other temperatures, pretest tubes under anticipated run conditions.
- If plastic containers are frozen before use, make sure that they are thawed to at least 2°C prior to centrifugation.

Table 1. Beckman Coulter Tubes and Bottles for the TLS-55 Rotor. Use only the items listed here.

Tube			Required Accessory		Max Speed/ RCF/ k Factor
Dimensions and Max Volume	Description	Part Number	Description	Part Number	
11 x 34 mm 2.2 mL	Ultra Clear	347356 (pkg/50)	none	—	55 000 rpm 259 000 x g 50
11 x 34 mm 2.2 mL	thinwall polyallomer	347357 (pkg/50)	none	—	55 000 rpm 259 000 x g 50
13 x 32 mm 2.0 mL	Quick-Seal polyallomer	344625 (pkg/50)	Noryl* floating spacer	344674	55 000 rpm 259 000 x g 50
11 x 25 mm 1.5 mL	Quick-Seal polyallomer	344624 (pkg/50)	Noryl floating spacer	344674	55 000 rpm 259 000 x g 37
11 x 34 mm 1.4 mL	thickwall polyallomer	347287 (pkg/100)	none	—	55 000 rpm 259 000 x g 50
11 x 34 mm 1.4 mL	thickwall polycarbonate	343778 (pkg/100)	none	—	55 000 rpm 259 000 x g 50
7 x 20 mm 230 µL	thickwall polycarbonate	343775 (pkg/100)	Delrin† adapter	358615 (pkg/4)	55 000 rpm 249 000 x g 23
7 x 20 mm 230 µL	thickwall cellulose propionate	342303 (pkg/100)	Delrin adapter	358615 (pkg/4)	55 000 rpm 249 000 x g 23
5 x 20 mm 175 µL	thinwall polyallomer	342630 (pkg/100)	Delrin adapter	358614 (pkg/4)	55 000 rpm 248 000 x g 22
5 x 20 mm 175 µL	thinwall cellulose propionate	341288 (pkg/100)	Delrin adapter	358614 (pkg/4)	55 000 rpm 248 000 x g 22
5 x 20 mm 175 µL	thinwall polyethylene	343622 (pkg/100)	Delrin adapter	358614 (pkg/4)	55 000 rpm 248 000 x g 22

*Noryl is a registered trademark of GE Plastics.

†Delrin is a registered trademark of E.I. DuPont de Nemours & Company.

Quick-Seal® Tubes



Quick-Seal tubes must be sealed prior to centrifugation. These tubes are heat sealed and do not need caps; however, spacers are required on top of the tubes when they are loaded into the rotor buckets.

- Fill Quick-Seal tubes leaving a *small* bubble of air at the base of the neck. Do not leave a large air space—too much air can cause excessive tube deformation.
- Refer to *Rotors and Tubes* for detailed information on the use and care of Quick-Seal tubes.

Some of the tubes listed in Table 1 are part of the *g*-Max™ system. The *g*-Max system uses a combination of small bell-top Quick-Seal tubes and floating spacers (also called *g*-Max spacers). This means that you can run the shorter tubes listed in the table in the TLS-55 rotor without reduction in *g* force. Additional information about the *g*-Max system is available in publication DS-709.

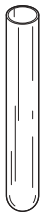

Open-Top Tubes

Open-top tubes should be filled as full as possible for tube support. If necessary, float mineral oil (or some other low-density, immiscible liquid) on top of the tube contents to fill the tube to its maximum volume. (Do not use an oil overlay in Ultra-Clear tubes.)

RUN TIMES

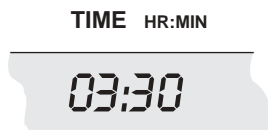

The *k* factor of the rotor is a measure of the rotor's pelleting efficiency. (Beckman Coulter has calculated the *k* factors for all of its preparative rotors at maximum rated speed and using full tubes.) The *k* factor is calculated from the formula:

$$k = \frac{\ln(r_{\max}/r_{\min})}{\omega^2} \times \frac{10^{13}}{3600} \quad (1)$$

where ω is the angular velocity of the rotor in radians per second ($\omega = 0.105 \times \text{rpm}$), r_{max} is the maximum radius, and r_{min} is the minimum radius.

After substitution:

$$k = \frac{(2.533 \times 10^{11}) \ln(r_{\text{max}}/r_{\text{min}})}{\text{rpm}^2} \quad (2)$$

Use the k factor in the following equation to estimate the run time t (in hours) required to pellet particles of known sedimentation coefficient s (in Svedberg units, S).

$$t = \frac{k}{s} \quad (3)$$

Run times can be estimated for centrifugation at less than maximum speed by adjusting the k factor as follows:

$$k_{\text{adj}} = k \left(\frac{55\,000}{\text{actual run speed}} \right)^2 \quad (4)$$

Run times can also be estimated from data established in prior experiments if the k factor of the previous rotor is known. For any two rotors, a and b:

$$\frac{t_a}{t_b} = \frac{k_a}{k_b} \quad (5)$$

For more information on k factors see *Use of k Factor for Estimating Run Times from Previously Established Run Conditions* (publication DS-719).

RUN SPEEDS



The centrifugal force at a given radius in a rotor is a function of speed. Comparisons of forces between different rotors are made by comparing the rotors' relative centrifugal fields (RCF). When rotational speed is adjusted so that identical samples are subjected to the same RCF in two different rotors, the samples are subjected to the same force. The RCF at a number of rotor speeds is provided in Table 2.

Table 2. Relative Centrifugal Fields for the TLS-55 Rotor.

Entries in this table are calculated from the formula

$$RCF = 1.12r (RPM/1000)^2$$

and then rounded to three significant digits.

Rotor Speed (rpm)	Relative Centrifugal Field (x g)			k Factor*
	At r_{max} (76.5 mm)	At r_{av} (59.4 mm)	At r_{min} (42.2 mm)	
55 000	259 000	201 000	143 000	50
50 000	214 000	166 000	118 000	60
45 000	174 000	135 000	95 700	74
40 000	137 000	106 000	75 600	94
35 000	105 000	81 500	57 900	116
30 000	77 100	59 900	42 500	123
25 000	53 600	41 500	29 500	167
20 000	34 300	26 600	18 900	241
15 000	19 300	15 000	10 600	377
10 000	8 570	6 650	4 730	690

*Calculated for all Beckman Coulter preparative rotors as a measure of the rotor's relative pelleting efficiency in water at 20°C.

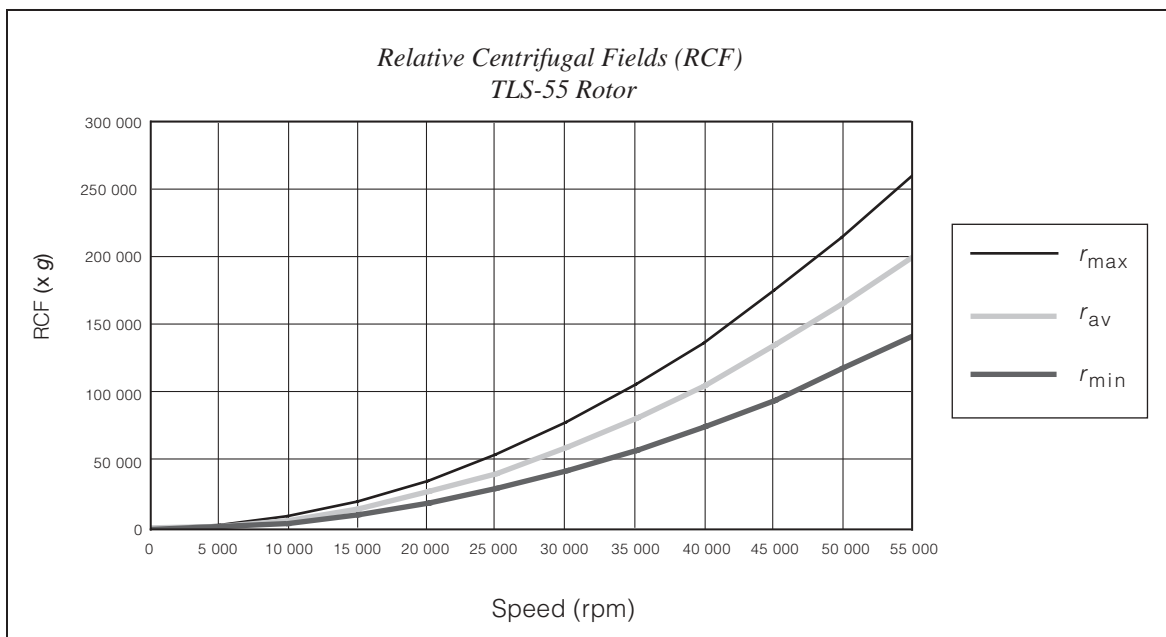

Do not select rotational speeds in excess of 55 000 rpm. In addition, speeds must be reduced under the following circumstances:

1. If nonprecipitating solutions more dense than 1.7 g/mL are centrifuged, reduce the maximum allowable run speed according to the following equation:

$$\text{reduced maximum speed} = (55\,000 \text{ rpm}) \sqrt{\frac{1.7 \text{ g/mL}}{\rho}} \quad (6)$$

where ρ is the density of the tube contents. This speed reduction will protect the rotor from excessive stresses due to the added tube load.

2. *Further speed limits must be imposed* when CsCl or other self-forming-gradient salts are centrifuged, as equation (6) does not predict concentration limits/speeds that are required to avoid precipitation of salt crystals. Solid CsCl has a density of 4 g/mL, and if precipitated during centrifugation may cause rotor failure. Figures 1 and 2, together with the description and examples below, show how to reduce run speeds when using CsCl gradients.

SELECTING CsCl GRADIENTS



Rotor speed is used to control the slope of a CsCl density gradient, and must be limited so that CsCl precipitation is avoided. Speed and density combinations that intersect on or below the curves in Figure 1 ensure that CsCl will not precipitate during centrifugation in the TLS-55 rotor. Curves are provided at two temperatures: 20°C (black curves) and 4°C (gray curves). Curves in Figures 1 and 2 are provided up to the maximum rated speed of the rotor.

NOTE

The curves in Figures 1 and 2 are for solutions of CsCl salt dissolved in distilled water only. If other salts are present in significant concentrations, the overall CsCl concentration may need to be reduced.

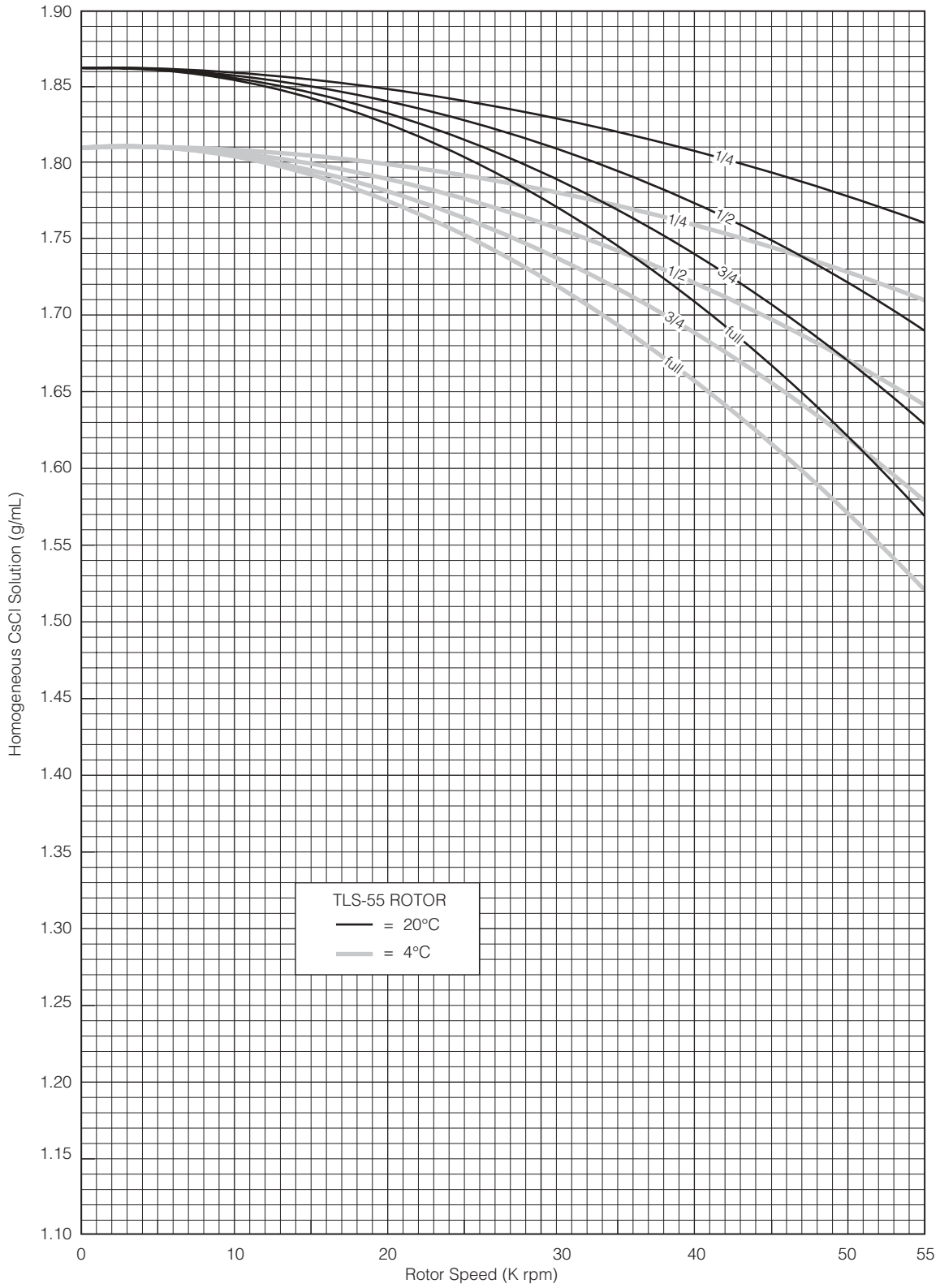

Figure 1. Precipitation Curves for the TLS-55 Rotor.
 Using combinations of rotor speeds and homogeneous CsCl solution densities that intersect on or below these curves ensures that CsCl will not precipitate during centrifugation.

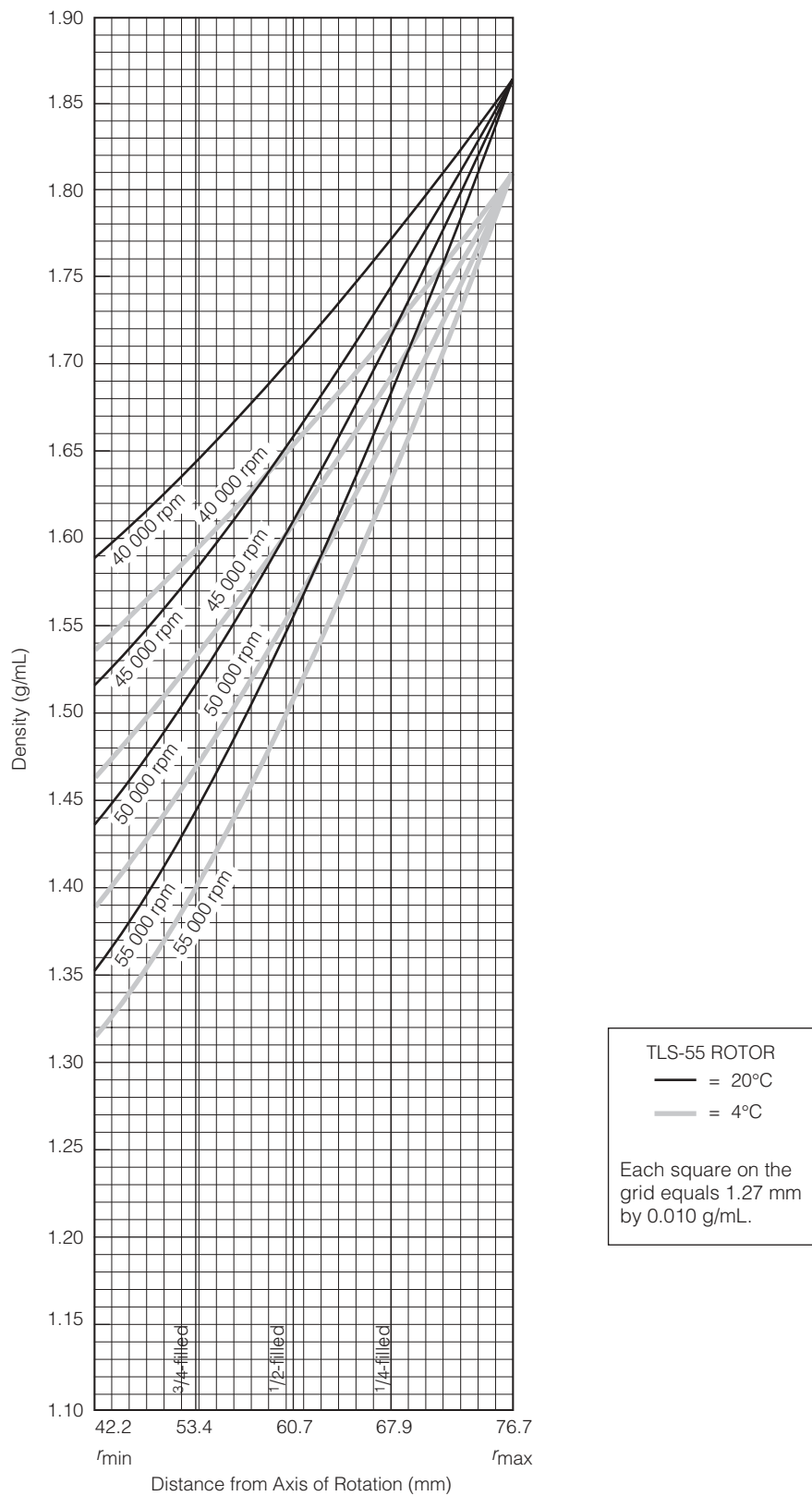
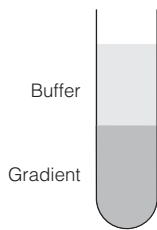

Figure 2. CsCl Gradients at Equilibrium for the TLS-55 Rotor. Centrifugation of homogeneous CsCl solutions at the maximum allowable speeds (from Figure 1) results in gradients presented here.

The reference curves in Figure 2 show gradient distribution at equilibrium. Each curve in Figure 2 is within the density limits allowed for the TLS-55 rotor: each curve was generated for a single run speed using the maximum allowable homogeneous CsCl densities (one for each fill level) that avoid precipitation at that speed. (The gradients in Figure 2 can be generated from step or linear gradients, or from homogeneous solutions. But the total amount of CsCl in solution must be equivalent to a homogeneous solution corresponding to the concentrations specified in Figure 2.) Figure 2 can also be used to approximate the banding positions of sample particles. Curves not shown in the figure may be interpolated.

ADJUSTING FILL VOLUMES



Figures 1 and 2 show that several fill volumes are possible in a tube. If a thinwall tube is partially filled with gradient solution, float mineral oil (or some other low-density, immiscible liquid) on top of the tube contents to fill the tube to its maximum volume. (Do not use an oil overlay in Ultra-Clear tubes.) Note that for a given CsCl density, as the fill level decreases the maximum allowable speed increases. Partial filling may be desirable when there is little sample or when you wish to shorten the run time.

For example, a *half-filled* tube of 1.62-g/mL homogeneous CsCl solution at 4°C may be centrifuged at 55 000 rpm (see Figure 1). The segment of the 55 000-rpm curve (Figure 2) from the half-filled line to the tube bottom represents this gradient. The same solution in a *three-quarter-filled* tube may be centrifuged no faster than 50 000 rpm. A tube *full* of the 1.62-g/mL CsCl solution may be centrifuged no faster than 44 000 rpm (curves not shown in the figure may be interpolated).

TYPICAL EXAMPLES FOR DETERMINING CsCl RUN PARAMETERS

Example A: Starting with a homogeneous CsCl solution density of 1.62 g/mL and approximate particle buoyant densities of 1.59 and 1.61 g/mL, at 20°C, where will particles band at equilibrium?

1. In Figure 1, find the curve that corresponds to the desired run temperature (20°C) and fill volume (full). The maximum allowable rotor speed is determined from the point where this curve intersects the homogeneous CsCl density (50 000 rpm).

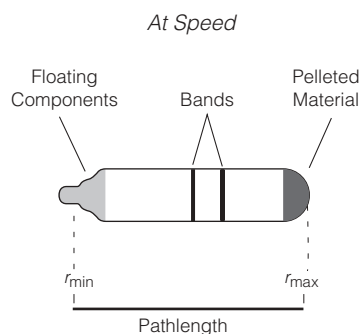

2. In Figure 2, sketch in a horizontal line corresponding to each particle's buoyant density.
3. Mark the point in the figure where each particle density intersects the curve corresponding to the selected run speed and temperature.
4. Particles will band at these locations across the tube diameter at equilibrium during centrifugation.

In this example, particles will band about 17.8 and 16.3 mm from the tube bottom (r_{\max}), about 1.5 mm of centerband-to-centerband separation.

To determine interband volume in milliliters, use the following equation:

$$V = \pi r^2 h \quad (7)$$

where r is the tube radius in centimeters and h is the interband separation in centimeters.

At Rest in Rotor



Example B: Knowing particle buoyant densities (for example, 1.49 and 1.52 g/mL), how do you achieve good separation?

At Rest Outside Rotor



1. In Figure 2, sketch in a horizontal line corresponding to each particle's buoyant density.
2. Select the curve at the desired temperature (4°C) and tube volume (full) that gives the best particle separation.
3. Note the run speed along the selected curve (55 000 rpm).
4. From Figure 1, select the maximum homogeneous CsCl density that corresponds to the temperature and run speed established above. These parameters will provide the particle-banding pattern selected in Step 2.

In this example, particles will band at about 17.0 and 15.3 mm from the tube bottom (about 1.7 mm apart).

CARE AND MAINTENANCE

MAINTENANCE

NOTE

Do not use sharp tools on the rotor that could cause scratches in the rotor surface. Corrosion begins in scratches and may open fissures in the rotor with continued use.

- Frequently check the bucket O-rings (841648) for signs of wear. Replace O-rings every 6 months, or whenever worn or damaged. Keep the O-rings lightly coated with silicone vacuum grease (335148).
- Regularly lubricate the bucket cap threads with a thin, even coat of Spinkote lubricant (306812) before every run.

Refer to Appendix A in *Rotors and Tubes* for the chemical resistances of rotor and accessory materials. Your Beckman Coulter representative provides contact with the Field Rotor Inspection Program and the rotor repair center.

CLEANING

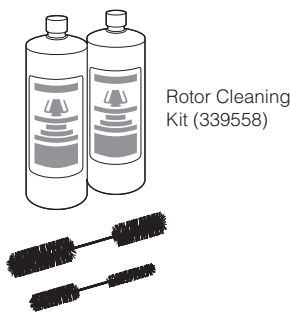

Wash the rotor and rotor components immediately if salts or other corrosive materials are used or if spillage has occurred. Do not allow corrosive materials to dry on the rotor.

Under normal use, wash the rotor frequently (at least weekly) to prevent buildup of residues.

1. Wash the rotor buckets, O-rings, and caps in a mild detergent, such as Beckman Solution 555™, that won't damage the rotor. The Rotor Cleaning Kit contains two plastic-coated brushes and two quarts of Solution 555 (339555) for use with rotors and accessories. Dilute the detergent 10 to 1 with water.
2. Wash the rotor body with a sponge or cloth dampened with a mild detergent, such as Solution 555, diluted 10 to 1 with water.

NOTE

Do not immerse the rotor body in water, since the hanger mechanism is difficult to dry and can rust.

3. Rinse the cleaned rotor and components with distilled water.
4. Air-dry the buckets upside down. *Do not use acetone to dry the rotor.*

Clean metal threads frequently to prevent buildup of residues and ensure adequate closure. Use a brush and concentrated Solution 555. Rinse and dry thoroughly, then lubricate lightly but evenly with Spinkote to coat all threads.

DECONTAMINATION



If the rotor or other components are contaminated with toxic, radioactive, or pathogenic materials, follow appropriate decontamination procedures as outlined by your laboratory safety officer. Refer to Appendix A in *Rotors and Tubes* to select solutions that will not damage the rotor and accessory materials.

STERILIZATION AND DISINFECTION

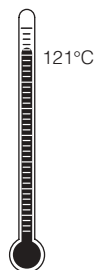

- The rotor and all rotor components can be autoclaved at 121°C for up to an hour. Remove the lids from the rotor buckets and place the rotor, buckets, lid, and spacers in the autoclave upside down.
- Ethanol (70%)* or hydrogen peroxide (6%) may be used on all rotor components, including those made of plastic. Bleach (sodium hypochlorite) may be used, but may cause discoloration of anodized surfaces. Use the minimum immersion time for each solution, per laboratory standards.

* Flammability hazard. Do not use in or near operating ultracentrifuges.

While Beckman Coulter has tested these methods and found that they do not damage the rotor or components, no guarantee of sterility or disinfection is expressed or implied. When sterilization or disinfection is a concern, consult your laboratory safety officer regarding proper methods to use.

Refer to publication IN-192 (included with each box of tubes) for tube sterilization and disinfection procedures. *Quick-Seal, Ultra Clear, and thinwall open-top tubes are disposable and should be discarded after a single use.*

STORAGE

When it is not in use, store the rotor in a dry environment (not in the instrument) with the bucket lids removed to allow air circulation so moisture will not collect in the tube cavities.

RETURNING A ROTOR

Before returning a rotor or accessory for any reason, prior permission (a Returned Goods Authorization form) must be obtained from Beckman Coulter, Inc. This RGA form may be obtained from your local Beckman Coulter sales office, and should contain the following information:

- serial number,
- history of use (approximate frequency of use),
- reason for the return,
- original purchase order number, billing number, and shipping number, if possible,
- name and phone number of the person to be notified upon receipt of the rotor or accessory at the factory, and,
- name and phone number of the person to be notified about repair costs, etc.

To protect our personnel, it is the customer's responsibility to ensure that all parts are free from pathogens and/or radioactivity. Sterilization and decontamination must be done before returning the parts. Smaller items (such as tubes, bottles, etc.) should be enclosed in a sealed plastic bag.

*All parts must be accompanied by a note, plainly visible on the outside of the box or bag, stating that they are safe to handle and that they are not contaminated with pathogens or radioactivity. **Failure to attach this notification will result in return or disposal of the items without review of the reported problem.***

Use the address label printed on the RGA form when mailing the rotor and/or accessories to:

Beckman Coulter, Inc.
1050 Page Mill Road
Palo Alto, CA 94304

Attention: Returned Goods

Customers located outside the United States should contact their local Beckman Coulter office.

SUPPLY LIST

NOTE

To obtain copies of referenced publications, contact Beckman Coulter, Inc., Technical Publications Department, 1050 Page Mill Road, Palo Alto, CA 94304, U.S.A. (Telephone 650-859-1753; Fax 650-859-1375).

Contact Beckman Coulter Sales (1-800-742-2345 in the United States; worldwide offices are listed on the back cover of this manual) or see the Beckman Coulter *Ultracentrifuge Rotors, Tubes & Accessories* catalog (BR-8101) for detailed information on ordering parts and supplies. For your convenience, a partial list is given below.

REPLACEMENT ROTOR PARTS

TLS-55 rotor assembly	346936
Buckets (set of 4).	346364
Bucket cap assembly	345770
Bucket O-ring (set of 4).	868638
Rotor stand	345773
Bucket stand	347358
Cap and plunger assembly.	349338

OTHER

Tubes and accessories	see Table 1
Tube rack	348305
Quick-Seal Cordless Tube Topper kit, 60 Hz	358312
Quick-Seal Cordless Tube Topper kit, 50 Hz (Europe).	358313
Quick-Seal Cordless Tube Topper kit, 50 Hz (Great Britain).	358314
Quick-Seal Cordless Tube Topper kit, 50 Hz (Australia)	358315
Tube Topper rack (11-mm dia. tubes).	349387
Floating spacer removal tool	338765
Tube removal tool (Quick-Seal tubes).	361668
Fraction Recovery System (for TL-series tubes).	347828
CentriTube Slicer.	347960
CentriTube Slicer blades (pkg of 10)	348299
Spinkote lubricant (2 oz)	306812
Silicone vacuum grease (1 oz).	335148
Rotor Cleaning Kit	339558
Beckman Solution 555 (1 qt)	339555
Rotor cleaning brush	339379

ULTRACENTRIFUGE ROTOR WARRANTY

All Beckman Coulter ultracentrifuge Fixed Angle, Vertical Tube, Near Vertical Tube, Swinging Bucket, and Airfuge rotors are warranted against defects in materials or workmanship for the time periods indicated below, subject to the Warranty Conditions stated below.

Preparative Ultracentrifuge Rotors 5 years — No Proration

Analytical Ultracentrifuge Rotors 5 years — No Proration

ML and TL Series Ultracentrifuge Rotors 5 years — No Proration

Airfuge Ultracentrifuge Rotors 1 year — No Proration

For Zonal, Continuous Flow, Component Test, and Rock Core ultracentrifuge rotors, see separate warranty.

Warranty Conditions (as applicable)

- 1) This warranty is valid for the time periods indicated above from the date of shipment to the original Buyer by Beckman Coulter or an authorized Beckman Coulter representative.
- 2) This warranty extends only to the original Buyer and may not be assigned or extended to a third person without written consent of Beckman Coulter.
- 3) This warranty covers the Beckman Coulter Centrifuge Systems only (including but not limited to the centrifuge, rotor, and accessories) and Beckman Coulter shall not be liable for damage to or loss of the user's sample, non-Beckman Coulter tubes, adapters, or other rotor contents.
- 4) This warranty is void if the Beckman Coulter Centrifuge System is determined by Beckman Coulter to have been operated or maintained in a manner contrary to the instructions in the operator's manual(s) for the Beckman Coulter Centrifuge System components in use. This includes but is not limited to operator misuse, abuse, or negligence regarding indicated maintenance procedures, centrifuge and rotor classification requirements, proper speed reduction for the high density of certain fluids, tubes, and tube caps, speed reduction for precipitating gradient materials, and speed reduction for high-temperature operation.
- 5) Rotor bucket sets purchased concurrently with or subsequent to the purchase of a Swinging Bucket Rotor are warranted only for a term co-extensive with that of the rotor for which the bucket sets are purchased.
- 6) This warranty does not cover the failure of a Beckman Coulter rotor in a centrifuge not of Beckman Coulter manufacture, or if the rotor is used in a Beckman Coulter centrifuge that has been modified without the written permission of Beckman Coulter, or is used with carriers, buckets, belts, or other devices not of Beckman Coulter manufacture.
- 7) Rotor parts subject to wear, including but not limited to rotor O-rings, VTi, NVT™, TLV, MLN, and TLN rotor tube cavity plugs and gaskets, tubing, tools, optical overspeed disks, bearings, seals, and lubrication are excluded from this warranty and should be frequently inspected and replaced if they become worn or damaged.
- 8) Keeping a rotor log is not mandatory, but may be desirable for maintenance of good laboratory practices.

Repair and Replacement Policies

- 1) If a Beckman Coulter rotor is determined by Beckman Coulter to be defective, Beckman Coulter will repair or replace it, subject to the Warranty Conditions. A replacement rotor will be warranted for the time remaining on the original rotor's warranty.
- 2) If a Beckman Coulter centrifuge is damaged due to a failure of a rotor covered by this warranty, Beckman Coulter will supply free of charge (i) all centrifuge parts required for repair (except the drive unit, which will be replaced at the then current price less a credit determined by the total number of revolutions or years completed, provided that such a unit was manufactured or rebuilt by Beckman Coulter), and (ii) if the centrifuge is currently covered by a Beckman Coulter warranty or Full Service Agreement, all labor necessary for repair of the centrifuge.
- 3) If a Beckman Coulter rotor covered by this warranty is damaged due to a malfunction of a Beckman Coulter ultracentrifuge covered by an Ultracentrifuge System Service Agreement, Beckman Coulter will repair or replace the rotor free of charge.
- 4) If a Beckman Coulter rotor covered by this warranty is damaged due to a failure of a Beckman Coulter tube, bottle, tube cap, spacer, or adapter, covered under the Conditions of this Warranty, Beckman Coulter will repair or replace the rotor and repair the instrument as per the conditions in policy point (2) above, and the replacement policy.
- 5) Damage to a Beckman Coulter rotor or instrument due to the failure or malfunction of a non-Beckman Coulter tube, bottle, tube cap, spacer, or adapter is not covered under this warranty, although Beckman Coulter will assist in seeking compensation under the manufacturer's warranty.

Disclaimer

IT IS EXPRESSLY AGREED THAT THE ABOVE WARRANTY SHALL BE IN LIEU OF ALL WARRANTIES OF FITNESS AND OF THE WARRANTY OF MERCHANTABILITY AND BECKMAN COULTER, INC. SHALL HAVE NO LIABILITY FOR SPECIAL OR CONSEQUENTIAL DAMAGES OF ANY KIND WHATSOEVER ARISING OUT OF THE MANUFACTURE, USE, SALE, HANDLING, REPAIR, MAINTENANCE, OR REPLACEMENT OF THE PRODUCT.

Factory Rotor Inspection Service

Beckman Coulter, Inc., will provide free mechanical and metallurgical inspection in Palo Alto, California, USA, of any Beckman Coulter rotor at the request of the user. (Shipping charges to Beckman Coulter are the responsibility of the user.) Rotors will be inspected in the user's laboratory if the centrifuge in which they are used is covered by an appropriate Beckman Coulter Service Agreement. Contact your local Beckman Coulter office for details of service coverage or cost.

Before shipping, contact the nearest Beckman Coulter Sales and Service office and request a Returned Goods Authorization (RGA) form and packaging instructions. Please include the complete rotor assembly, with buckets, lid, handle, tube cavity caps, etc. A SIGNED STATEMENT THAT THE ROTOR AND ACCESSORIES ARE NON-RADIOACTIVE, NON-PATHOGENIC, NON-TOXIC, AND OTHERWISE SAFE TO SHIP AND HANDLE IS REQUIRED.

Beckman Coulter Worldwide Life Science Research Division Offices

AUSTRALIA

Beckman Coulter Australia Pty Ltd
Unit D, 24 College St.
Gladesville, NSW 2111
Australia
Telephone: (61) 2 9844-6000
or toll free: 1 800 060 880
Fax: (61) 2 9844-6096
email: lifescienceaustralia@beckman.com

CANADA

Beckman Coulter (Canada) Inc.
6755 Mississauga Road, Suite 600
Mississauga, Ontario
Canada L5N 7Y2
Telephone: (905) 819-1234
Fax: (905) 819-1485

CHINA

Beckman Coulter Inc.
Beijing Representative Office
Unit 2005A, 2006-2009, East Ocean Center
Jian Guomenwai Avenue
Beijing 100004
China
Telephone: (86) 10 6515 6028
Fax: (86) 10 6515 6025, 6515 6026

EASTERN EUROPE/ MIDDLE EAST/AFRICA

Beckman Coulter International S.A.
22, Rue Juste-Olivier
Case Postale 301-303
CH-1260 Nyon, Switzerland
Telephone: (41) 22 994 07 07
Fax: (41) 22 994 07 00

FRANCE

Beckman Coulter France S.A.
Paris Nord II, 33/66 rue des Vanesses
B.P. 50359
Villepinte, France
95942 ROISSY CDG Cedex
Telephone: 01 49 90 90 00
Fax: 01 49 90 90 10
e-mail: bioresearch.france@beckman.com

GERMANY

Beckman Coulter GmbH
Siemensstrasse 1
D-85716 Unterschleissheim-Lohhof
Germany
Telephone: (89) 35870-0
Fax: (89) 35870-490
e-mail: bioresearch.de@beckman.com

HONG KONG

Beckman Coulter Hong Kong Ltd.
12th Floor, Oxford House
979 King's Road
Taikoo Place, Hong Kong
Telephone: (852) 2814 7431, 2814 0481
Fax: (852) 2814 1599, 2873 4511

ITALY

Beckman Coulter S.p.a.
Centro Direzionale Lombardo
Palazzo F/1, Via Roma 108
20060 Cassina de' Pecchi
Milano, Italy
Telephone: 02-953921
Fax: 02-95392264
e-mail: beckman_italia@beckman.com

JAPAN

Beckman Coulter K.K.
Toranomon 37 Mori Bldg.
3-5-1, Toranomon
Minato-ku, Tokyo 105-0001
Japan
Telephone: 03-5404-8359
Fax: 03-5404-8436

MEXICO

Beckman Coulter de Mexico S.A DE C.V
Avenida Popocatepetl #396
Colonia Gral. Pedro Maria Anaya
Codigo Postal 03340
Maxico, D.F. Mexico
Telephone: 525 605-77-70
Fax: 525 575-18-25

NETHERLANDS

Beckman Coulter Nederland B.V.
Nijverheidsweg 21
3641 RP-Mijdrecht
Postbus 47
3640 AA Mijdrecht
The Netherlands
Telephone: 0297-230630
Fax: 0297-288082

SINGAPORE

Beckman Coulter Singapore Pte. Ltd.
116 Changi Road
Unit #03-01/02
Singapore 419718
Telephone: (65) 339 3633
Fax: (65) 336 6303

SOUTH AFRICA

Beckman Coulter
Stand 1A Primegro Park
Tonetti Street
1685 Halfway House
Johannesburg
Republic of South Africa
Telephone: (27) 11-805-2014/5
Fax: (27) 11-805-4120

SPAIN

Beckman Coulter España S.A.
C/ Caleruega, 81
28033 Madrid, Spain
Telephone: (34) 91 3836080
Fax: (34) 91 3836096
email: bioresearch.espana@beckman.com

SWEDEN

Beckman Coulter AB
Archimedesvaegen 7
Box 111 56
SE-168 11 Bromma
Sweden
Telephone: (0)8 564 85 900
Telefax: (0)8 564 85 901

SWITZERLAND

Beckman Coulter International S.A.
22, Rue Juste-Olivier
Case Postale 301-303
CH-1260 Nyon
Switzerland
Telephone: 0800 850 810
Fax: 0848 850 810

TAIWAN

Beckman Coulter Taiwan Inc.
Taiwan Branch
8th Floor
216 Tun Hwa South Road, Section 2
Taipei 106, Taiwan
Republic of China
Telephone: (886) 2 2378 3456
Fax: (886) 2 2377 0408

TURKEY

Beckman Coulter Ltd.
E-5 Yanyol Faith Cad.
81410 Soganlik Kartal
Istanbul
Turkey
Telephone: 90 216 309 1900
Fax: 90 216 309 0090

UNITED KINGDOM

Beckman Coulter United Kingdom Ltd
Oakley Court
Kingsmead Business Park
London Road
High Wycombe
Bucks HP11 1JU
England, U.K.
Telephone: 01494 441181
Fax: 01494 447558
e-mail: beckman_uk@beckman.com

Authorized dealers in other countries.



Beckman Coulter, Inc. • 4300 N. Harbor Boulevard, Box 3100 • Fullerton, California 92834-3100

Sales: 1-800-742-2345 • Service: 1-800-551-1150 • Internet: www.beckmancoulter.com • Telex: 678413 • Fax: 1-800-643-4366



Printed on recycled paper

©2001 Beckman Coulter, Inc.



I.S. EN ISO 9001